



TEST REPORT

Applicant: Shenzhen Ur-Health Technology Co.,Ltd.

Address: No.1,Shisheng Road,Kengzi Street,Pingshan Dist,Shenzhen,Guangdong,China

Manufacturer: Shenzhen Ur-Health Technology Co.,Ltd.

Address: No.1, Shisheng Road, Kengzi Street, Pingshan Dist, Shenzhen, Guangdong, China

EUT: Large Home Air Purifier

Brand Name: N/A

Model Number: URHAF-809

Date of Receipt: Jun. 11, 2020

Test Date: Jun. 11, 2020 - Jun. 28, 2020

Date of Report: Jun. 28, 2020

Prepared By: Shenzhen DL Testing Technology Co., Ltd.

Address: 101-201, Building C, Shuanghuan, No.8, Baoqing Road, Baolong Industrial Zone,Baolong Street Longgang District, Shenzhen, Guangdong, China

Applicable Standards: EN 55014-1:2017
EN 61000-3-2:2019, EN 61000-3-3:2013+A1:2019
EN 55014-2:2015
EN 61000-4-2:2009, EN 61000-4-3: 2019, EN 61000-4-4:2012,
EN 61000-4-5:2014+A1:2017, EN 61000-4-6:2014/AC:2015, EN 61000-4-11:2019

Test Result: Pass

Report Number: DL-2020061974E

Prepared by(Engineer): Jack Bu

Reviewer(Supervisor): Nico Zou

Approved(Manager): Jade Yang



This test report is based on a single evaluation of one sample of above mentioned products. It is not permitted to be duplicated in extracts without written approval of Shenzhen DL Testing Technology Co., Ltd.



TABLE OF CONTENT

Test Report Declaration	Page
1. VERSION.....	4
2. TEST SUMMARY.....	4
3. GENERAL INFORMATION.....	5
3.1 Description of Device (EUT).....	5
3.2 Tested System Details.....	5
3.3 Test Mode Description.....	5
3.4 Test Uncertainty.....	5
4. TEST INSTRUMENT USED.....	6
5. CONDUCTED EMISSION AT THE MAINS TERMINALS TEST.....	8
5.1 Block Diagram Of Test Setup	8
5.2 Test Standard and Limit	8
5.3 EUT Configuration on Test.....	8
5.4 Operating Condition of EUT	9
5.5 Test Procedure	9
5.6 Test Result	9
6. DISTURBANCE POWER EMISSION TEST	12
6.1 Block Diagram Of Test Setup	12
6.2 Test Standard and Limit	12
6.3 EUT Configuration on Test.....	12
6.4 Operating Condition of EUT	12
6.5 Test Procedure	13
6.6 Test Result	13
7. RADIATION EMISSION TEST	14
7.1 Block Diagram of Test Setup.....	14
7.2 Test Standard and Limit	14
7.3 EUT Configuration on Test.....	14
7.4 Operating Condition of EUT	15
7.5 Test Procedure	15
7.6 Test Result	15
8. HARMONIC CURRENT EMISSION TEST.....	18
8.1 Block Diagram of Test Setup.....	18
8.2 Test Standard.....	18
8.3 Operating Condition of EUT	18
8.4 Test Procedure	18
8.5 Test Results	18
9. VOLTAGE FLUCTUATIONS & FLICKER TEST	19
9.1 Block Diagram of Test Setup.....	19
9.2 Test Standard.....	19



9.3	Operating Condition of EUT	19
9.4	Test Procedure	19
9.5	Test Results	19
10.	IMMUNITY TEST OF GENERAL THE PERFORMANCE CRITERIA.....	20
11.	ELECTROSTATIC DISCHARGE IMMUNITY TEST.....	21
11.1	Block Diagram of Test Setup.....	21
11.2	Test Standard.....	21
11.3	Severity Levels and Performance Criterion.....	21
11.4	Test Procedure	21
11.5	Test Results.....	22
12.	RF FIELD STRENGTH SUSCEPTIBILITY TEST	23
12.1	Block Diagram of Test Setup	23
12.2	Test Standard.....	23
12.3	Severity Levels and Performance Criterion.....	23
12.4	Test Procedure	23
12.5	Test Results.....	24
13.	ELECTRICAL FAST TRANSIENT/BURST IMMUNITY TEST.....	25
13.1	Block Diagram of EUT Test Setup	25
13.2	Test Standard.....	25
13.3	Severity Levels and Performance Criterion.....	25
13.4	Test Procedure	25
13.5	Test Results.....	26
14.	SURGE TEST.....	27
14.1	Block Diagram of EUT Test Setup	27
14.2	Test Standard.....	27
14.3	Severity Levels and Performance Criterion.....	27
14.4	Test Procedure	27
14.5	Test Result.....	28
15.	INJECTED CURRENTS SUSCEPTIBILITY TEST	29
15.1	Block Diagram of EUT Test Setup	29
15.2	Test Standard.....	29
15.3	Severity Levels and Performance Criterion.....	29
15.4	Test Procedure	29
15.5	Test Result.....	30
16.	VOLTAGE DIPS AND INTERRUPTIONS TEST.....	31
16.1	Block Diagram of EUT Test Setup	31
16.2	Test Standard.....	31
16.3	Severity Levels and Performance Criterion.....	31
16.4	Test Procedure	31
16.5	Test Result.....	32
17.	SETUP PHOTOGRAPHS.....	33
18.	EUT PHOTOGRAPHS	35



1. VERSION

Version No.	Date	Description
00	Jun. 28, 2020	Original

2. TEST SUMMARY

EMC Emission				
Standard	Test Item	Limit	Result	Remark
EN 55014-1	Conducted Emission at power ports	-----	PASS	
	Conducted Emission at load terminals	-----	N/A	
	Disturbance power Emission	-----	N/A	
	Radiated Emission below 1GHz	-----	PASS	
EN 61000-3-2	Harmonic Current Emission	Class A or D	N/A	
EN 61000-3-3	Voltage Fluctuations & Flicker	-----	PASS ^{NOTE (2)}	
EMC Immunity				
Section EN 55014-2	Test Item	Performance Criteria	Result	Remark
EN 61000-4-2	Electrostatic Discharge	B	PASS	
EN 61000-4-3	RF electromagnetic field	A	PASS	
EN 61000-4-4	Fast transients	B	PASS	
EN 61000-4-5	Surges	B	PASS	
EN 61000-4-6	Injected Current	A	PASS	
EN 61000-4-11	Volt. Interruptions Volt. Dips	C / C / C	PASS	

NOTE (3)

NOTE:

(1) "N/A" denotes test is not applicable in this Test Report

(2) The power consumption of EUT is less than 75W and no Limits apply.

(3) Voltage dip: 70% reduction – Performance Criteria B

Voltage Interruptions: 30% reduction – Performance Criteria C

(4) Test Facility: Shenzhen DL Testing Technology Co., Ltd.

Address: Part One of 301, A-2 Factory Building, Yalijia Industrial Plant, No. 87, Hengping Road, Yuanshan Street, Longgang District, Shenzhen, China



3. GENERAL INFORMATION

3.1 Description of Device (EUT)

EUT : Large Home Air Purifier
Brand Name : N/A
Model Number : URHAF-809
Model difference : N/A
Power Supply : AC 220-240V 50Hz
Working Frequency : Below 15MHz

3.2 Tested System Details

None.

3.3 Test Mode Description

Mode1. On Mode

3.4 Test Uncertainty

Conducted Emission Uncertainty : ± 2.57 dB

Radiated Emission Uncertainty : ± 4.51 dB



4. TEST INSTRUMENT USED

For Conducted and Disturbance power Emission Test (843 Shielded Room)

Equipment	Manufacturer	Model	Serial	Last Cal.	Next Cal.
843 Shielded Room	ChengYu	843 Room	843	Nov. 25, 2019	Nov. 24, 2022
EMI Receiver	R&S	ESR	101421	Dec. 06, 2019	Dec. 05, 2020
LISN	R&S	ENV216	102417	Dec. 06, 2019	Dec. 05, 2020
Clamp	COM-POWER	CLA-050	431071	Dec. 06, 2019	Dec. 05, 2020
843 Cable 1#	ChengYu	CE Cable	001	Dec. 06, 2019	Dec. 05, 2020
843 Cable 1#	ChengYu	CE Cable	002	Dec. 06, 2019	Dec. 05, 2020

For Radiated Emission Test (966 chamber)

Equipment	Manufacturer	Model	Serial	Last Cal.	Next Cal.
966 chamber	ChengYu	966 Room	966	Nov. 25, 2019	Nov. 24, 2022
Spectrum Analyzer	Agilent	E4408B	MY50140780	Dec. 06, 2019	Dec. 05, 2020
EMI Receiver	R&S	ESRP7	101393	Dec. 06, 2019	Dec. 05, 2020
Amplifier	Schwarzbeck	BBV9743B	00153	Dec. 06, 2019	Dec. 05, 2020
Amplifier	EMEC	EM01G8GA	00270	Dec. 06, 2019	Dec. 05, 2020
Broadband Trilog Antenna	Schwarzbeck	VULB9162	00306	Dec. 06, 2019	Dec. 05, 2020
Horn Antenna	Schwarzbeck	BBHA9120D	02139	Dec. 06, 2019	Dec. 05, 2020
966 Cable 1#	ChengYu	966	004	Dec. 06, 2019	Dec. 05, 2020
966 Cable 2#	ChengYu	966	003	Dec. 06, 2019	Dec. 05, 2020

For Harmonic & Flicker Test (EMS --- site)

Equipment	Manufacturer	Model	Serial	Last Cal.	Next Cal.
Harmonics, Flicker & power Analyser	LAPLACE INSTRUMENTS	AC2000A	311370	Dec. 06, 2019	Dec. 05, 2020
AC Power Supply	MToni	HPF5010	633659	Dec. 06, 2019	Dec. 05, 2020

For Electrostatic Discharge Immunity Test (EMS --- site)

Equipment	Manufacturer	Model	Serial	Last Cal.	Next Cal.
ESD Tester	SCHLODER	SESD 230	17352	Dec. 06, 2019	Dec. 05, 2020

**For RF Field Strength Susceptibility Test (Keyway --- site)**

Equipment	Manufacturer	Model	Serial	Last Cal.	Next Cal.
Signal Generator	HP	8648A	3625U00573	Sep. 26, 2019	Sep. 26, 2020
Amplifier	A&R	500A100	17034	Sep. 26, 2019	Sep. 26, 2020
Amplifier	A&R	100W/1000M1	17028	Sep. 26, 2019	Sep. 26, 2020
Audio Analyzer (20Hz~1GHz)	Panasonic	2023B	202301/428	Sep. 26, 2019	Sep. 26, 2020
Isotropic Field Probe	A&R	FP2000	16755	Sep. 26, 2019	Sep. 26, 2020
Antenna	EMCO	3108	9507-2534	Sep. 26, 2019	Sep. 26, 2020
Log-periodic Antenna	A&R	AT1080	16812	Sep. 26, 2019	Sep. 26, 2020

For EFT /B, Surge, Voltage Dips Interruptions Test (EMS --- site)

Equipment	Manufacturer	Model	Serial	Last Cal.	Next Cal.
Transient Comprehensive Immunity Test System	Graphtec	HVIP16T+HCO MPACT 5	192501+192202	Dec. 06, 2019	Dec. 05, 2020
Coupling Clamp	HTEC	001	0001	Dec. 06, 2019	Dec. 05, 2020

For Injected Currents Susceptibility Test (EMS --- site)

Equipment	Manufacturer	Model	Serial	Last Cal.	Next Cal.
C/S Test System	LIONCEL	RIS-6091-85	0191101	Dec. 06, 2019	Dec. 05, 2020
CDN	LIONCEL	CDN-M2-16	0191001	Dec. 06, 2019	Dec. 05, 2020
CDN	LIONCEL	CDN-M3-16	0191002	Dec. 06, 2019	Dec. 05, 2020
Injection Clamp	Frankonia	EMCL-20	18101728-0108	Dec. 06, 2019	Dec. 05, 2020

5. CONDUCTED EMISSION AT THE MAINS TERMINALS TEST

5.1 Block Diagram Of Test Setup

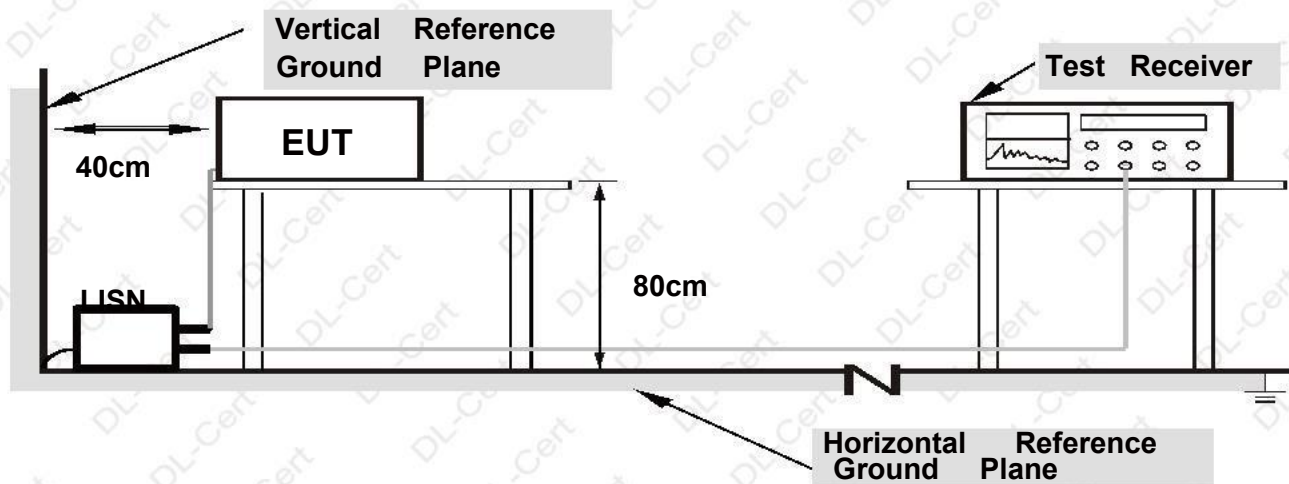

- Note:**
- 1.Support units were connected to second LISN.
 - 2.Both of LISNs (AMN) are 80 cm from EUT and at least 80 from other units and other metal planes

5.2 Test Standard and Limit

EN 55014-1

Frequency MHz	Limits dB(☒)			
	At mains terminals		At load terminals and additional terminals	
	Quasi-peak Level	Average Level	Quasi-peak Level	Average Level
0.15~0.50	66 ~ 56*	59 ~ 46*	80	70
0.50~5.00	56	46	74	64
5.00~30.00	60	50	74	64

- Notes:**
1. *Decreasing linearly with logarithm of frequency.
 2. The lower limit shall apply at the transition frequencies.

5.3 EUT Configuration on Test

The following equipment's are installed on conducted emission test to meet EN 55014-1 requirement and operating in a manner which tends to maximize its emission characteristics in a normal application.



5.4 Operating Condition of EUT

5.5.1 Setup the EUT and simulators as shown in Section 5.1.

5.5.2 Turn on the power of all equipments.

5.5.3 Let the EUT work in test modes and test it.

5.5 Test Procedure

The EUT is put on the ground and connected to the AC mains through a Artificial Mains Network (AMN). This provided a 50ohm coupling impedance for the tested equipments. Both sides of AC line are checked to find out the maximum conducted emission levels according to the **EN 55014-1** regulations during conducted emission test.

The bandwidth of the test receiver (R&S Test Receiver ESR) is set at 10KHz.

The frequency range from 150 KHz to 30 MHz is investigated.

5.6 Test Result

PASS

Please refer to the following page.



Conducted Emission Test Data			
Temperature:	24.5°C	Relative Humidity:	54%
Pressure:	1009hPa	Phase :	Line
Test Voltage:	AC 230V/50Hz	Test Mode:	ON Mode

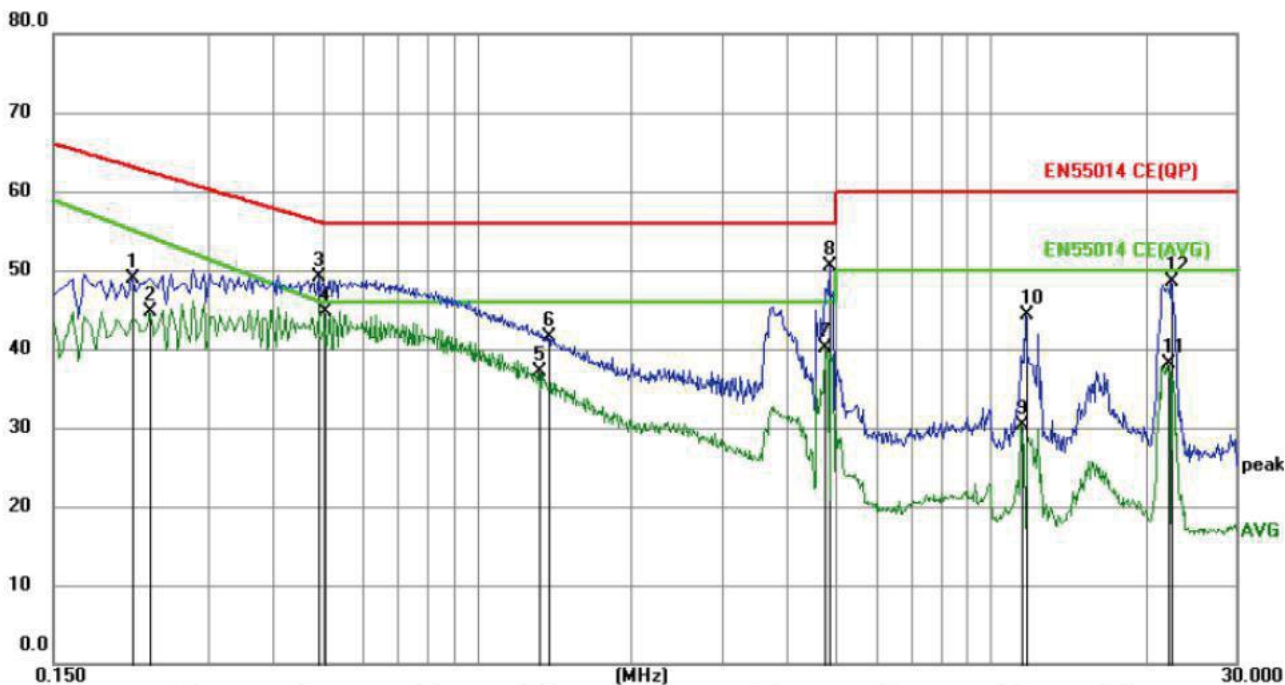

No.	Frequency (MHz)	Reading (dBuV)	Factor (dB)	Level (dBuV)	Limit (dBuV)	Margin (dB)	Detector
1	0.2130	38.35	10.51	48.86	63.09	-14.23	QP
2	0.2310	34.15	10.51	44.66	54.34	-9.68	AVG
3	0.4920	38.52	10.52	49.04	56.13	-7.09	QP
4	0.5055	34.17	10.52	44.69	46.00	-1.31	AVG
5	1.3200	26.90	10.24	37.14	46.00	-8.86	AVG
6	1.3784	31.18	10.24	41.42	56.00	-14.58	QP
7	4.7670	29.70	10.32	40.02	46.00	-5.98	AVG
8	4.8525	40.17	10.33	50.50	56.00	-5.50	QP
9	11.4855	19.54	10.69	30.23	50.00	-19.77	AVG
10	11.6835	33.70	10.69	44.39	60.00	-15.61	QP
11	22.0965	27.32	10.76	38.08	50.00	-11.92	AVG
12	22.4700	37.79	10.75	48.54	60.00	-11.46	QP



Conducted Emission Test Data			
Temperature:	24.5°C	Relative Humidity:	54%
Pressure:	1009hPa	Phase :	Neutral
Test Voltage:	AC 230V/50Hz	Test Mode:	ON Mode

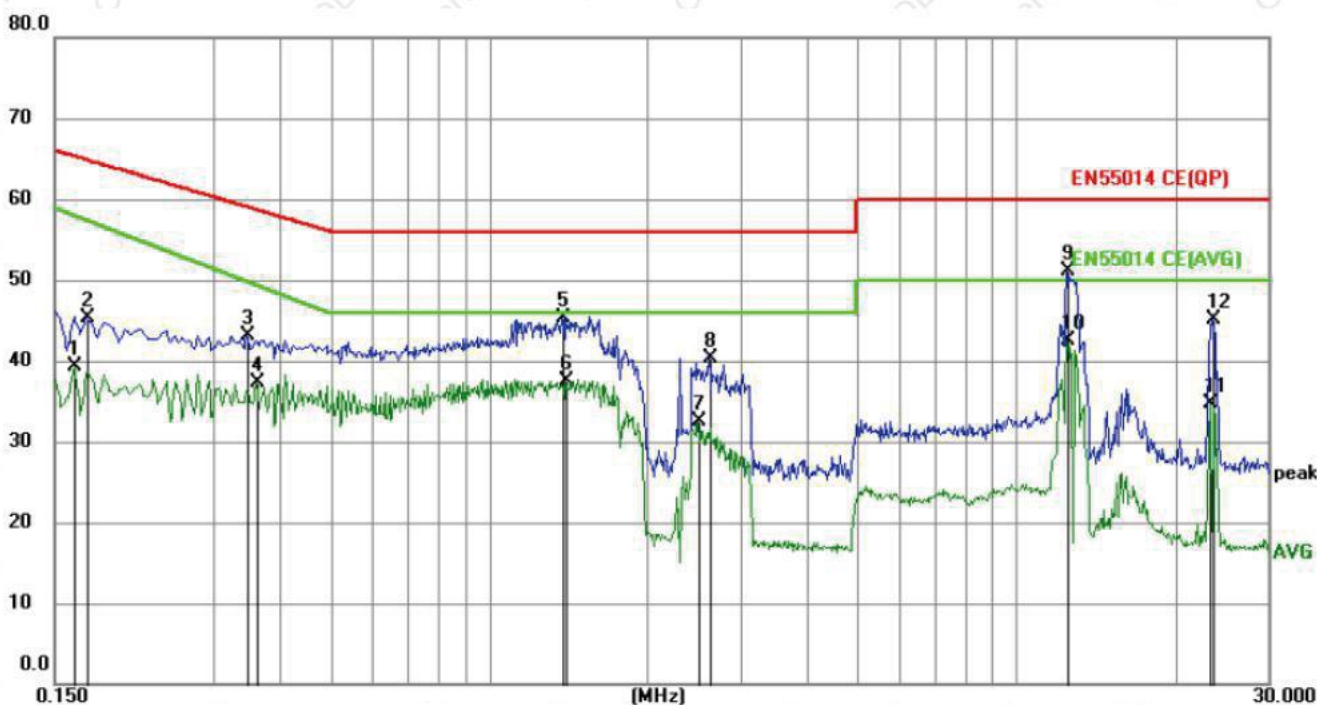

No.	Frequency (MHz)	Reading (dBuV)	Factor (dB)	Level (dBuV)	Limit (dBuV)	Margin (dB)	Detector
1	0.1635	28.82	10.51	39.33	58.07	-18.74	AVG
2	0.1725	34.76	10.51	45.27	64.84	-19.57	QP
3	0.3480	32.64	10.52	43.16	59.01	-15.85	QP
4	0.3615	26.84	10.52	37.36	49.50	-12.14	AVG
5	1.3785	35.10	10.24	45.34	56.00	-10.66	QP
6	1.3965	27.31	10.24	37.55	46.00	-8.45	AVG
7	2.4990	22.25	10.27	32.52	46.00	-13.48	AVG
8	2.6115	29.95	10.27	40.22	56.00	-15.78	QP
9	12.4530	40.40	10.70	51.10	60.00	-8.90	QP
10	12.4530	31.72	10.70	42.42	50.00	-7.58	AVG
11	23.2755	23.92	10.73	34.65	50.00	-15.35	AVG
12	23.5995	34.43	10.73	45.16	60.00	-14.84	QP

6. DISTURBANCE POWER EMISSION TEST

6.1 Block Diagram Of Test Setup

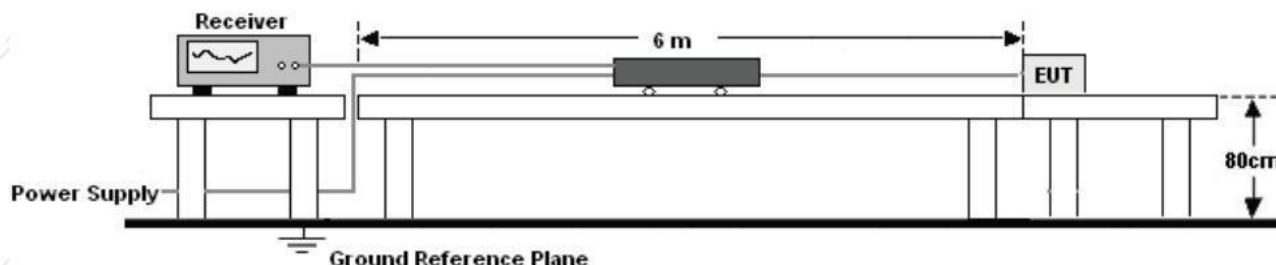

6.2 Test Standard and Limit

EN 55014-1

Frequency MHz	Limits dB(pW)	
	Quasi-peak Level	Average Level
30-300	45-55	35-45

Notes: The limit Increasing linearly with the frequency from 30 to 300 MHz.

Margin when performing disturbance power Measurement in the frequency range 30 MHz to 300 MHz

Frequency MHz	Margin Quasi-peak dB(pW)
	Household and similar appliances / Tools
200 to 300	0 to 10

Note: The limit Increasing linearly with the frequency from 200 to 300 MHz.

6.3 EUT Configuration on Test

The following equipment's are installed on conducted emission test to meet EN 55014-1 requirement and operating in a manner which tends to maximize its emission characteristics in a normal application.

6.4 Operating Condition of EUT

5.5.1 Setup the EUT and simulators as shown in Section 6.1.

5.5.2 Turn on the power of all equipments.

5.5.3 Let the EUT work in test modes and test it.



6.5 Test Procedure

- a. The absorbing clamp was placed around the lead to be measured, with its current transformer towards the equipment under test.
- b. All connectors having a connected lead shall be terminated in a manner representative of use.
- c. The absorbing clamp was applied successively to all leads whose length is 25cm or longer, unscreened or screened, which may be connected to the individual units of the equipment under test.
- d. The Product was placed on a nonconductive table of 0.8 m of height above the floor and at least 0.8m from other metallic objects and from any person. The lead to be measured shall be stretched in a straight horizontal line for length sufficient to accommodate the absorbing clamp.
- e. Pre-scans were performed with a quasi-peak detector and an average detector.
- f. At each test frequency the absorbing clamp shall be moved along the lead until the maximum value is found between a position adjacent to the equipment under test and a distance of about a half wavelength from it.

The bandwidth of the test receiver (R&S Test Receiver ESR) is set at 10KHz.

6.6 Test Result

PASS

The product meets the requirements of Section 7, so no testing in this section.

7. RADIATION EMISSION TEST

7.1 Block Diagram of Test Setup

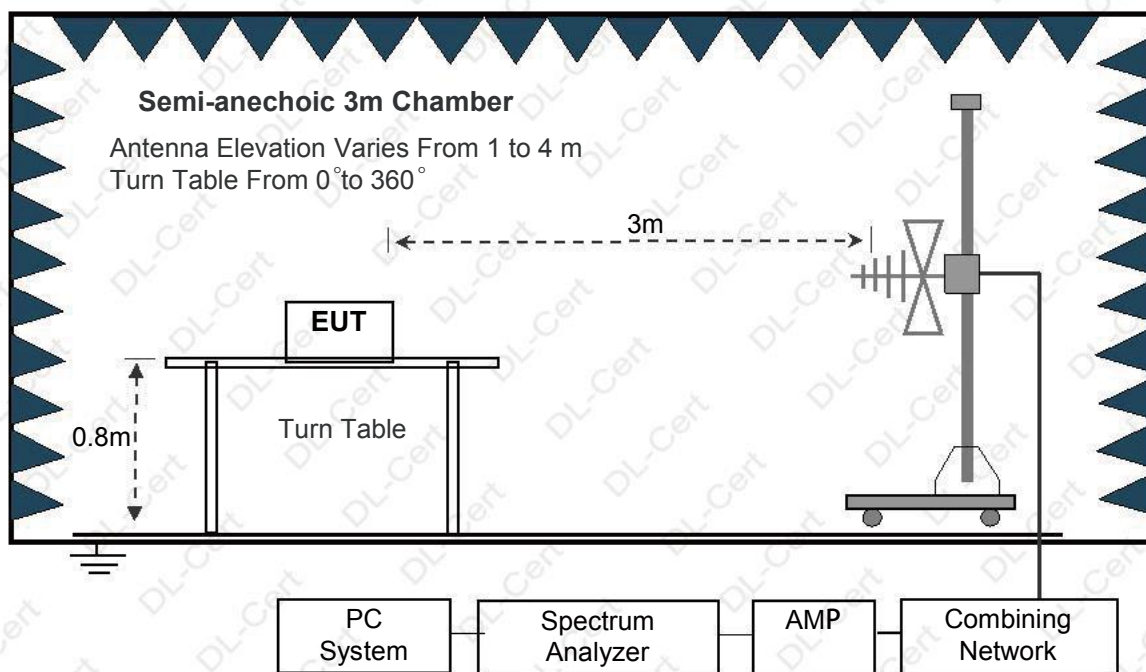

7.2 Test Standard and Limit

EN 55014-1

Frequency MHz	Distance (Meters)	Field Strengths Limits dB(μV)/m
30~230	3	40.0
230~1000	3	47.0

Remark:

- (1) The smaller limit shall apply at the cross point between two frequency bands.
- (2) Distance refers to the distance in meters between the measuring instrument, antenna and the closed point of any part of the device or system.

7.3 EUT Configuration on Test

The EN 55014-1 regulations test method must be used to find the maximum emission during radiated emission test.

The configuration of EUT is the same as used in conducted emission test. Please refer to Section 2.2.



7.4 Operating Condition of EUT

Same as conducted emission test, which is listed in Section 2.2 except the test set up replaced as Section 4.1.

7.5 Test Procedure

- 1) The radiated emissions test was conducted in a semi-anechoic chamber.
- 2) The tabletop EUT was placed upon a non-metallic table 0.8m above the ground reference plane. And for floor-standing arrangement, the EUT was placed on the horizontal ground reference plane, but separated from metallic contact with the ground reference plane by 0.1m of insulation.
- 3) Before final measurements of radiated emissions, a pre-scan was performed in the spectrum mode with the peak detector to find out the maximum emissions spectrum plots of the EUT.
- 4) The frequencies of maximum emission were determined in the final radiated emissions measurement. At each frequency, the EUT was rotated 360°, and the antenna was raised and lowered from 1 to 4 meters in order to determine the maximum disturbance. Measurements were performed for both horizontal and vertical antenna polarization.
- 5) The bandwidth setting on the field strength meter (R&S Test Receiver ESCI) is set at 120KHz.
- 6) The frequency range from 30MHz to 1000MHz is checked.

7.6 Test Result

PASS

Please refer to the following page.



Radiation Emission Test Data			
Temperature:	24.5°C	Relative Humidity:	54%
Pressure:	1009hPa	Polarization :	Horizontal
Test Voltage:	AC 230V/50Hz	Test Mode:	ON Mode

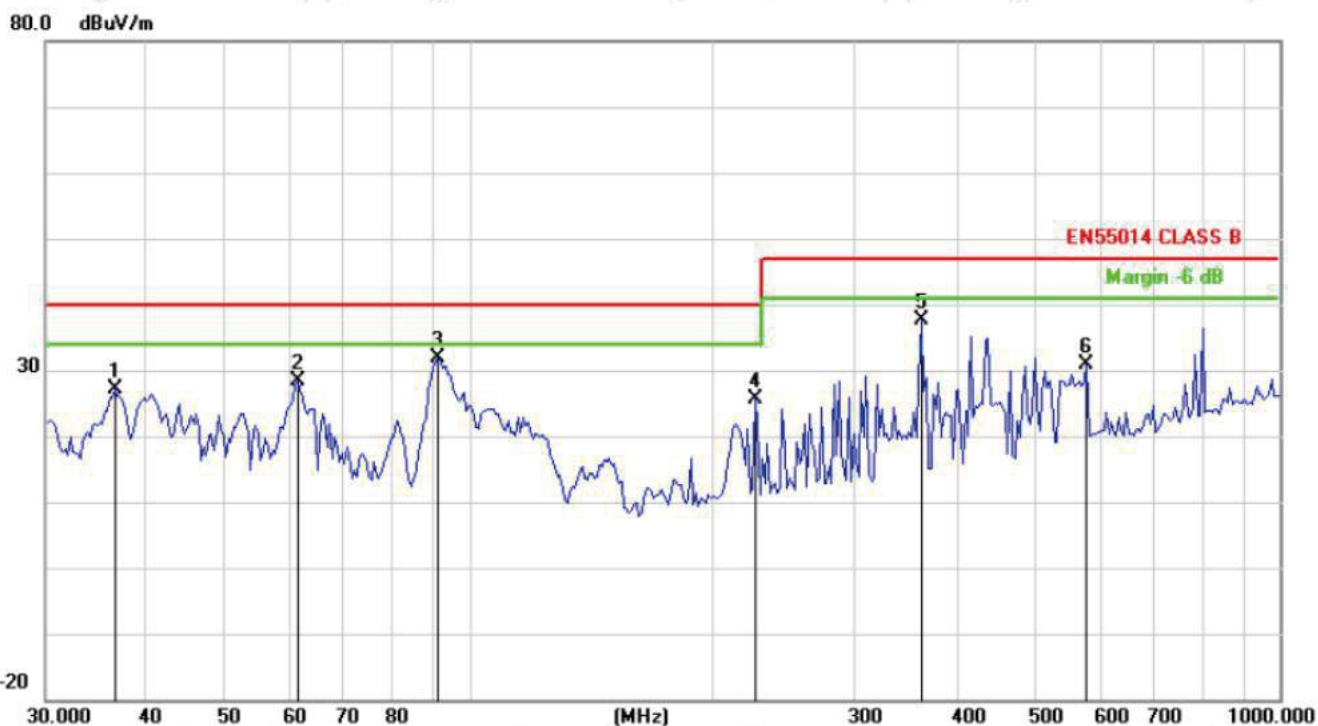

No.	Mk.	Freq. MHz	Reading Level dBuV	Correct Factor dB	Measure- ment dBuV/m	Limit dB/	Margin dB	Detector	Antenna Height cm	Table Degree degree	Comment
1		36.5236	41.67	-14.54	27.13	40.00	-12.87	QP			
2		61.4343	42.89	-14.47	28.42	40.00	-11.58	QP			
3	*	91.6994	48.96	-17.02	31.94	40.00	-8.06	QP			
4		225.4267	40.30	-14.65	25.65	40.00	-14.35	QP			
5		360.9775	48.72	-11.14	37.58	47.00	-9.42	QP			
6		578.0359	37.73	-6.92	30.81	47.00	-16.19	QP			



Radiation Emission Test Data			
Temperature:	24.5°C	Relative Humidity:	54%
Pressure:	1009hPa	Polarization :	Vertical
Test Voltage:	AC 230V/50Hz	Test Mode:	ON Mode



No. Mk.	Freq. MHz	Reading Level dBuV	Correct Factor dB	Measurement dBuV/m	Limit dB/	Margin dB	Detector	Antenna Height cm	Table Degree degree	Comment
1 *	36.5236	49.64	-14.74	34.90	40.00	-5.10	QP			
2	61.0041	44.01	-14.96	29.05	40.00	-10.95	QP			
3	93.6529	42.13	-16.68	25.45	40.00	-14.55	QP			
4	124.9248	33.04	-17.78	15.26	40.00	-24.74	QP			
5	261.2730	35.44	-13.62	21.82	47.00	-25.18	QP			
6	403.9334	33.12	-10.33	22.79	47.00	-24.21	QP			

8. HARMONIC CURRENT EMISSION TEST

8.1 Block Diagram of Test Setup

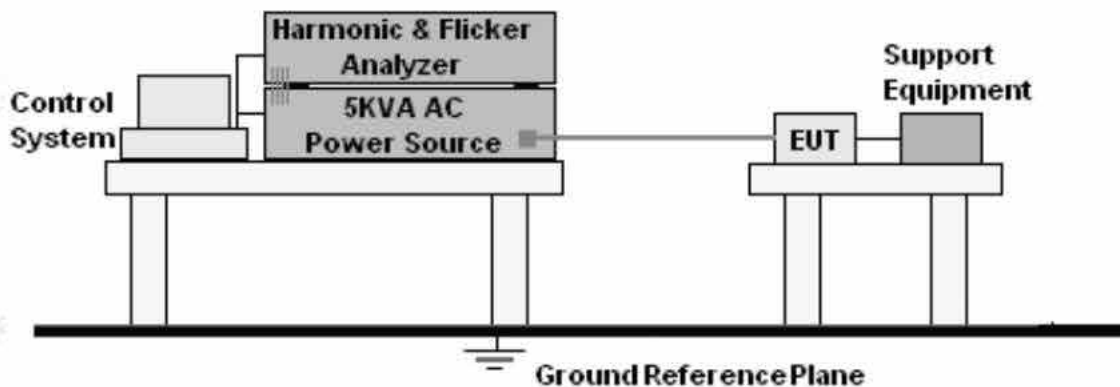

8.2 Test Standard

EN 61000-3-2

8.3 Operating Condition of EUT

Setup the EUT as shown in Section 8.1.
Turn on the power of all equipments.
Let the EUT work in test mode and test it.

8.4 Test Procedure

The power cord of the EUT is connected to the output of the test system. Turn on the power of the EUT and use the test system to test the harmonic current level.

8.5 Test Results

PASS

Please refer to the following page.

There is no need for Harmonic current test to be performed on this product (rated power is less than 75 W) in accordance with EN 61000-3-2.

For further details, please refer to Clause 7 of EN 61000-3-2 which states:

“For the following categories of equipment, limits are not specified in this standard:

- equipment with a rated power of 75 W or less, other than lighting equipment.”



9. VOLTAGE FLUCTUATIONS & FLICKER TEST

9.1 Block Diagram of Test Setup

Same as Section 8.1.

9.2 Test Standard

EN 61000-3-3

9.3 Operating Condition of EUT

Same as Section 8.3. The power cord of the EUT is connected to the output of the test system. Turn on the power of the EUT and use the test system to test the harmonic current level.

Flicker Test Limit

Test items	Limits
Pst	1.0
dc	3.3%
Tmax	4.0%
dt	Not exceed 3.3% for 500ms

9.4 Test Procedure

The power cord of the EUT is connected to the output of the test system. Turn on the power of the EUT and use the test system to test the harmonic current level.

9.5 Test Results

Flicker Test Data			
Temperature:	24.5°C	Relative Humidity:	54%
Test Voltage:	AC 230V/50Hz	Test Mode:	ON Mode

Voltage Fluctuation	Limit	Value
Relative Voltage Change Characteristic Tmax (dc > 3%)	500 ms	0 ms
Maximum Relative Voltage Change dmax	4%	0.00
	6%	/
	7%	/
Relative Steady-state Voltage Change dc	3.3%	0.00

Flicker	Limit	Value
Short-term Flicker Indicator Pst	1.0	0.063
Long-term Flicker Indicator Plt	0.65	/



10. IMMUNITY TEST OF GENERAL THE PERFORMANCE CRITERIA

Product Standard	EN 55014-2
CRITERION A	The apparatus shall continue to operate as intended during the test. No degradation of performance or loss of function is allowed below a performance level (or permissible loss of performance) specified by the manufacturer, when the apparatus is used as intended. If the minimum performance level or the permissible performance loss is not specified by the manufacturer, then either of these may be derived from the product description and documentation, and from what the user may reasonably expect from the apparatus if used as intended
CRITERION B	The apparatus shall continue to operate as intended after the test. No degradation of performance or loss of function is allowed below a performance level (or permissible loss of performance) specified by the manufacturer, when the apparatus is used as intended. During the test, degradation of performance is allowed, however, no change of actual operating state or stored data is allowed. If the minimum performance level or the permissible performance loss is not specified by the manufacturer, then either of these may be derived from the product description and documentation, and from what the user may reasonably expect from the apparatus if used as intended.
CRITERION C	Temporary loss of function is allowed, provided the function is self-recoverable or can be restored by the operation of the controls, or by any operation specified in the instructions for use.

11. ELECTROSTATIC DISCHARGE IMMUNITY TEST

11.1 Block Diagram of Test Setup

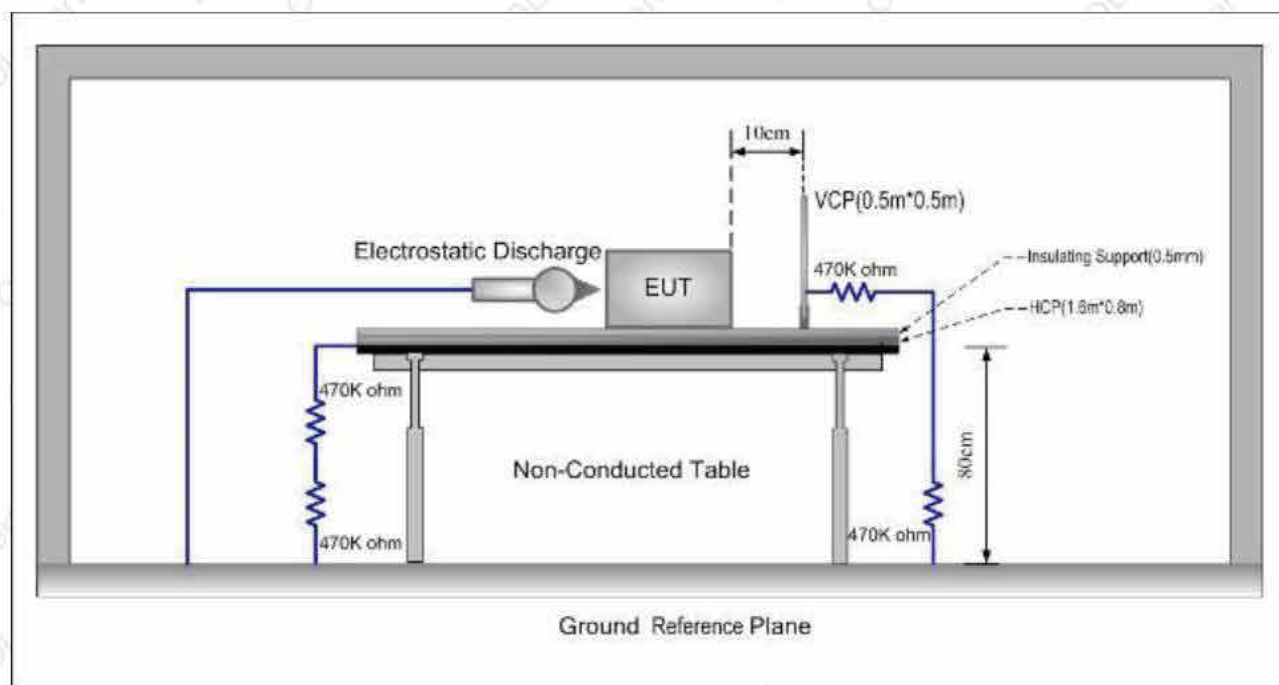

11.2 Test Standard

EN 55014-2, EN 61000-4-2

11.3 Severity Levels and Performance Criterion

Severity Level: 3 / Air Discharge: $\pm 8\text{KV}$

Level: 2 / Contact Discharge: $\pm 4\text{KV}$

Performance criterion : B

11.4 Test Procedure

- Electrostatic discharges were applied only to those points and surfaces of the Product that are accessible to users during normal operation.
- The test was performed with at least ten single discharges on the pre-selected points in the most sensitive polarity.
- The time interval between two successive single discharges was at least 1 second.
- The ESD generator was held perpendicularly to the surface to which the discharge was applied and the return cable was at least 0.2 meters from the Product.
- Contact discharges were applied to the non-insulating coating, with the pointed tip of the generator penetrating the coating and contacting the conducting substrate.
- Air discharges were applied with the round discharge tip of the discharge electrode approaching the Product as fast as possible (without causing mechanical damage) to touch the Product. After each discharge, the ESD generator was removed from



the Product and re-triggered for a new single discharge. The test was repeated until all discharges were complete.

- g. At least ten single discharges (in the most sensitive polarity) were applied to the Horizontal Coupling Plane at points on each side of the Product. The ESD generator was positioned vertically at a distance of 0.1 meters from the Product with the discharge electrode touching the HCP.
- h. At least ten single discharges (in the most sensitive polarity) were applied to the center of one vertical edge of the Vertical Coupling Plane in sufficiently different positions that the four faces of the Product were completely illuminated. The VCP (dimensions 0.5m x 0.5m) was placed vertically to and 0.1 meters from the Product.

11.5 Test Results

PASS

Please refer to the following page.

Electrostatic Discharge Test Data					
Temperature:	25.1°C	Humidity:	55%		
Power Supply :	AC 230V/50Hz	Test Mode:	ON Mode		
Discharge Method	Discharge Position	Voltage (±kV)	Min. No. of Discharge per polarity (Each Point)	Required Level	Result
Contact Discharge	Conductive Surfaces	4	10	B	Pass
	Indirect Discharge HCP	4	10	B	Pass
	Indirect Discharge VCP	4	10	B	Pass
Air Discharge	Slots, Apertures, and Insulating Surfaces	8	10	B	Pass
Note: N/A					

12. RF FIELD STRENGTH SUSCEPTIBILITY TEST

12.1 Block Diagram of Test Setup

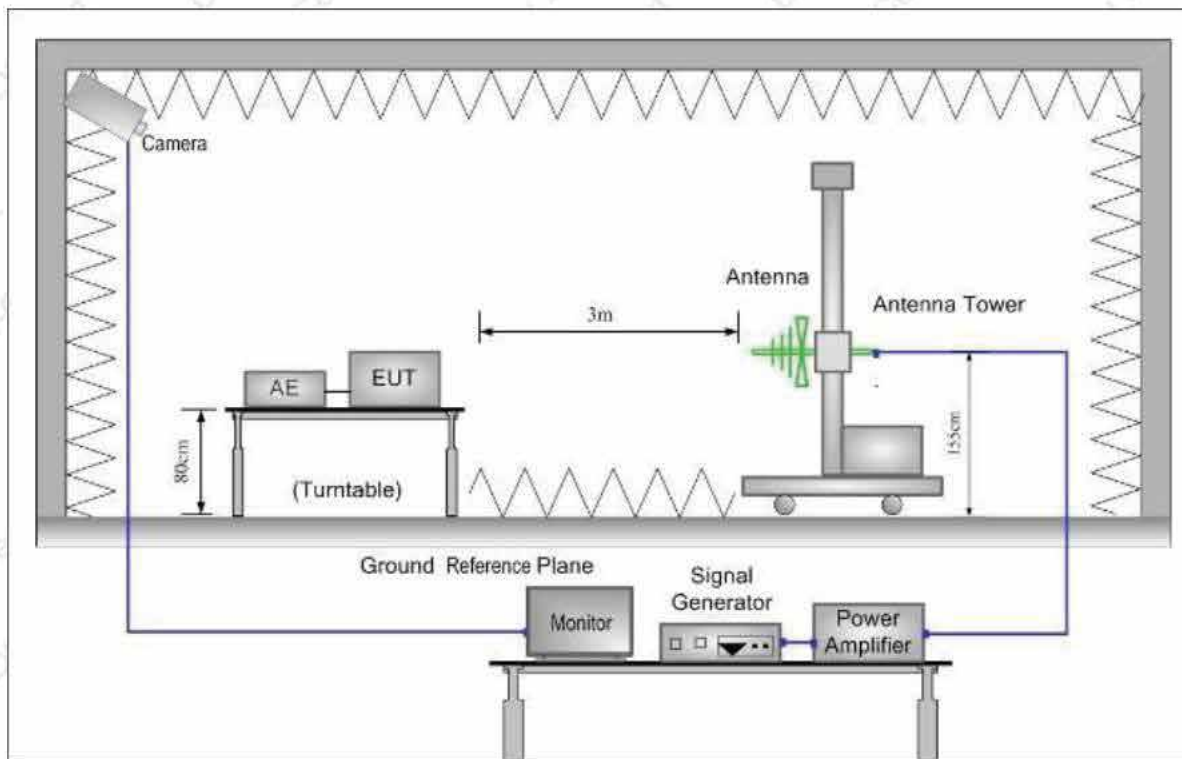

12.2 Test Standard

EN 55014-2, EN 61000-4-3

12.3 Severity Levels and Performance Criterion

Severity Level 2, 3V / m
Performance criterion: A

12.4 Test Procedure

The EUT and its simulators are placed on a turn table which is 0.8 meter above ground. EUT is set 3 meter away from the transmitting antenna which is mounted on an antenna tower. Both horizontal and vertical polarization of the antenna are set on test. Each of the four sides of EUT must be faced this transmitting antenna and measured individually.



All the scanning conditions are as follows:

Condition of Test	Remarks
Fielded Strength	3 V/m (Severity Level 2)
Radiated Signal	Modulated
Scanning Frequency	80 – 1000 MHz
Dwell time of radiated	0.0015 decade/s
Waiting Time	1 Sec.

12.5 Test Results

PASS

Please refer to the following page.

R/S Test Data				
Temperature:	25.1℃	Humidity:	55%	
Power Supply :	AC 230V/50Hz	Test Mode:	ON Mode	
Criterion:	A	Steps	1 %	
Frequency (MHz)	Position	Field Strength (V/m)	Required Level	Result
80 – 1000	Front, Right, Back, Left	3	A	Pass
Note: N/A				

13. ELECTRICAL FAST TRANSIENT/BURST IMMUNITY TEST

13.1 Block Diagram of EUT Test Setup

For input a.c. / d.c. power port:

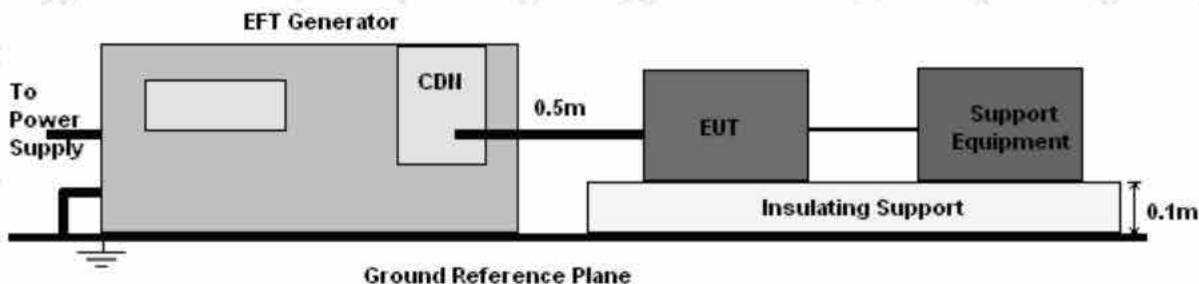

For signal lines and control lines:

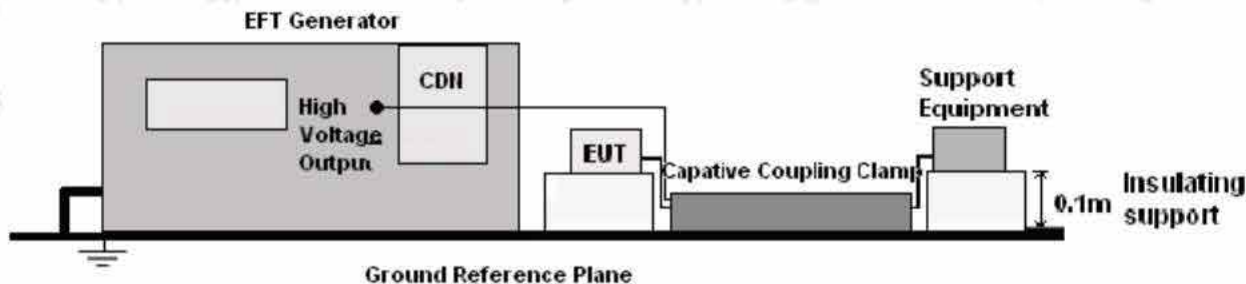

13.2 Test Standard

EN 55014-2, EN 61000-4-4

13.3 Severity Levels and Performance Criterion

Severity Level 2 at 1KV, Pulse Rise time & Duration: 5 nS / 50 nS

Performance criterion: B

13.4 Test Procedure

EUT shall be placed 0.8m high above the ground reference plane which is a min. 1m*1m metallic sheet with 0.65mm minimum thickness. This reference ground plane shall project beyond the EUT by at least 0.1m on all sides and the minimum distance between EUT and all other conductive structure, except the ground plane beneath the EUT, shall be more than 0.5m



For input and output AC power ports:

The EUT is connected to the power mains by using a coupling device which couples the EFT interference signal to AC power lines. Both polarities of the test voltage should be applied during compliance test and the duration of the test is 2 minutes.

13.5 Test Results

PASS

Please refer to the following page.

EFT Test Data			
Temperature:	24.5°C	Humidity:	53%
Power Supply :	AC 230V/50Hz	Test Mode:	ON Mode
Coupling Line	Test Voltage(kV)	Performance Criterion	Result
L	±0.5, 1	B	PASS
N	±0.5, 1	B	PASS
L-N	±0.5, 1	B	PASS



14. SURGE TEST

14.1 Block Diagram of EUT Test Setup

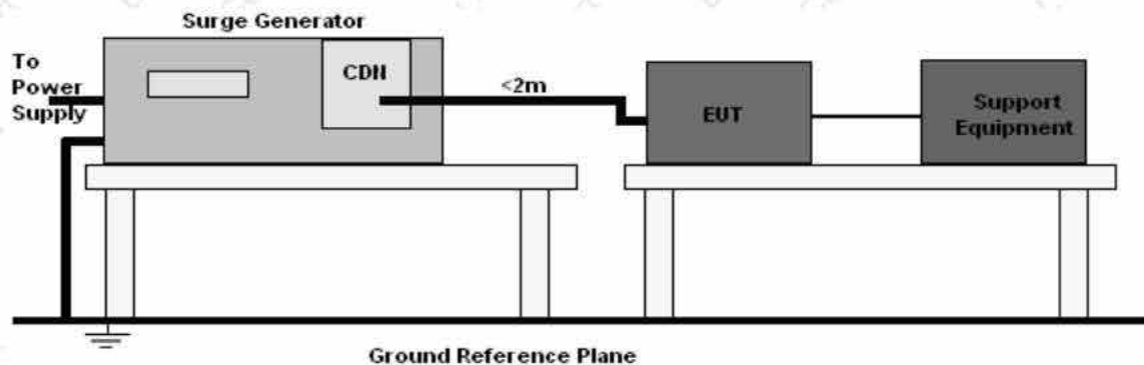

14.2 Test Standard

EN 55014-2, EN61000-4-5

14.3 Severity Levels and Performance Criterion

Severity Level: Line to Line, Level 2 at 1KV;
Severity Level: Line to Earth, Level 3 at 2KV.

Performance criterion: B

14.4 Test Procedure

- 1) Set up the EUT and test generator as shown on section 11.1
- 2) For line to line coupling mode, provide a 1KV 1.2/50us voltage surge (at open-circuit condition) and 8/20us current surge to EUT selected points.
- 3) At least 5 positive and 5 negative (polarity) tests with a maximum 1/min repetition rate are conducted during test.
- 4) Different phase angles are done individually.
- 5) Repeat procedure 2) to 4) except the open-circuit test voltage change from 1KV to 2KV for line to earth coupling mode test.
- 6) Record the EUT operating situation during compliance test and decide the EUT immunity criterion for above each test.



14.5 Test Result

PASS

Please refer to the following page.

Surge Test Data						
Temperature:	24.5°C		Humidity:	53%		
Power Supply :	AC 230V/50Hz		Test Mode:	ON Mode		
Location	Polarity	Phase Angle	No of Pulse	Pulse Voltage (KV)	Performance Criterion	Result
L-N	+	90	5	0.5,1	B	Pass
L-N	-	270	5	0.5,1	B	Pass
Note: N/A						

15. INJECTED CURRENTS SUSCEPTIBILITY TEST

15.1 Block Diagram of EUT Test Setup

For input a.c. / d.c. power port:

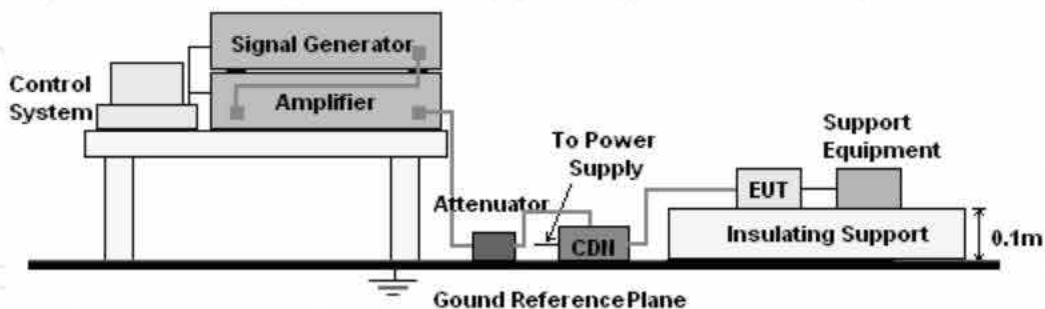

For signal lines and control lines:

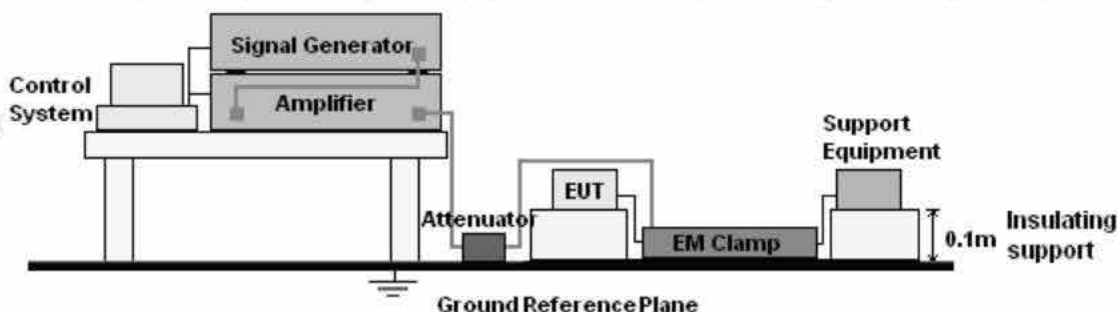

15.2 Test Standard

EN 55014-2, EN61000-4-6

15.3 Severity Levels and Performance Criterion

Severity Level 2: 3V(rms), 150KHz ~ 80MHz

Performance criterion: A

15.4 Test Procedure

- 1) Set up the EUT, CDN and test generator as shown on section 12.1
- 2) Let EUT work in test mode and measure.
- 3) The EUT and supporting equipments are placed on an insulating support 0.1m high above a ground reference plane. CDN (coupling and decoupling device) is placed on the ground plane at above 0.1-0.3m from EUT. Cables between CDN and EUT are as short as possible, and their height above the ground reference plane shall be



between 30 and 50 mm (where possible).

4) The disturbance signal described below is injected to EUT through CDN.

5) The EUT operates within its operational mode(s) under intended climatic conditions after power on.

6) The frequency range is swept from 150KHz to 80MHz using 3V signal level, and with the disturbance signal 80% amplitude modulated with a 1KHz sine wave

7) The rate of sweep shall not exceed 1.5×10^3 decades/s. Where the frequency is swept incrementally, the step size shall not exceed 1% of the start and thereafter 1% of the preceding frequency value.

8) Recording the EUT operating situation during compliance test and decide the EUT immunity criterion for above each test.

15.5 Test Result

PASS

Please refer to the following page.

CS Test Data						
Temperature:		24.5°C		Humidity:		53%
Power Supply :		AC 230V/50Hz		Test Mode:		ON Mode
Frequency Range(MHz)	Injected Position	Strength	Modulation Signal	Freq. Step	Performance Criterion	Result
0.15~80	AC Line	3V(rms), Unmodulated	AM 80%, 1kHz sine wave	1%	A	Pass
0.15~80	DC Line, Signal Line	3V(rms), Unmodulated	AM 80%, 1kHz sine wave	1%	/	/
Note: N/A						



16. VOLTAGE DIPS AND INTERRUPTIONS TEST

16.1 Block Diagram of EUT Test Setup

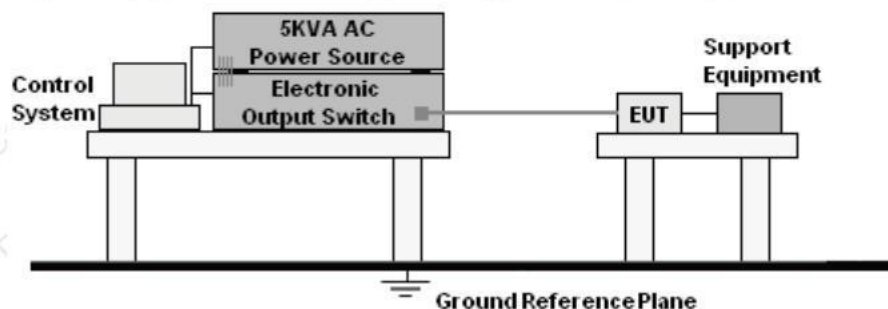

16.2 Test Standard

EN 55014-2, EN61000-4-11

16.3 Severity Levels and Performance Criterion

Input and Output AC Power Ports.

- Voltage Dips.
- Voltage Interruptions.

Environmental Phenomena	Test Specification	Units	Performance Criterion
Voltage Dips	100	% Reduction period	C
	0.5		
	60	% Reduction period	C
	10		
	30	% Reduction period	C
	25		

16.4 Test Procedure

- 1) Set up the EUT and test generator as shown on section 14.1
- 2) The interruption is introduced at selected phase angles with specified duration.
There is a 3mins minimum interval between each test event.
- 3) After each test a full functional check is performed before the next test.
- 4) Repeat procedures 2 & 3 for voltage dips, only the level and duration is changed.
- 5) Record any degradation of performance.



16.5 Test Result

PASS

Please refer to the following page.

DIPS Test Data				
Temperature:	24.5°C	Humidity:	53%	
Power Supply :	AC 230V/50Hz	Test Mode:	ON Mode	
Environmental Phenomena	Test Specification	Units	Performance Criterion	Result
Voltage Dips	100 0.5	% Reduction period	C	Pass
	60 10	% Reduction period	C	Pass
	30 25	% Reduction period	C	Pass



17. EUT PHOTOGRAPHS

